

## MV-BP Series

● 85°C 2,000Hrs assured.

- Vertical SMD type.
- Bi-Polarized
- EMV-BP Series : Ecological capacitors with the same characteristics as MV-BP

Solvent-proof

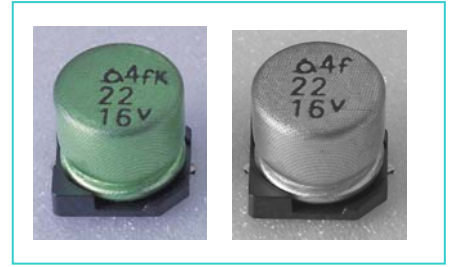

## MVK-BP Series

● 105°C 1,000Hrs assured.

- Vertical SMD type.
- Bi-Polarized
- Wide Temperature Range
- EMVK Series : Ecological capacitors with the same characteristics as MVK-BP

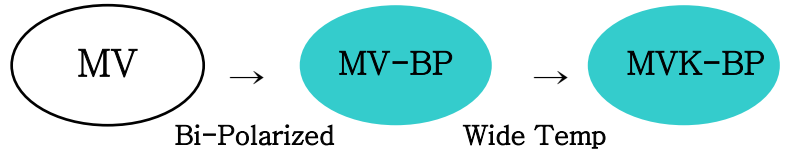

## SPECIFICATIONS

Item	Characteristics							
Series Name	MV-BP			MVK-BP				
Rated Voltage Range	4 ~ 50Vdc			6.3 ~ 50Vdc				
Operating Temperature Range	-40 ~ +85°C			-40 ~ +105°C				
Capacitance Tolerance	±20% (M) (at 20°C, 120Hz)							
Leakage Current (In Both Direction)	I = 0.05CV or 10µA, whichever is greater Where, I : Max. Leakage current (µA), C : Nominal capacitance(µF), V: Rated voltage(V <sub>DC</sub> ) (at 20°C, 2 minutes)							
Dissipation Factor(Tanδ)	Rated Voltage(V <sub>DC</sub> )	4	6.3	10	16	25	35~50	
	MV-BP	0.45	0.32	0.26	0.24	0.22	0.20	
	MVK-BP	-	0.35	0.26	0.24	0.20	0.18	
(at 20°C, 120Hz)								
Temperature Characteristics (Impedance ratio)	Rated Voltage(V <sub>DC</sub> )	4	6.3	10	16	25	35~50	
	Z (-25°C) / Z (20°C)	7	4	3	2	2	2	
	Z (-40°C) / Z (20°C)	15	10	8	6	4	3	
(at 120Hz)								
Load Life	The following specifications shall be satisfied when the capacitors are restored to 20°C after the rated voltage applied with the following conditions with its polarization reversed every 250 hours.							
	Series Name	MV-BP			MVK-Bp			
	Test time & Temperature	2,000 hours at 85°C			1,000 hours at 105°C			
	Capacitance change	≤ ± 20% of the initial value			≤ ± 30% of the initial value			
	Tanδ	≤ ±200% of the initial specified value			≤ ±300% of the initial specified value			
	Leakage Current	≤ The initial specified value			≤ The initial specified value			

Shelf Life	The following specifications shall be satisfied when the capacitors are restored to 20°C after exposing them for 500 hours at 85°C(MV-BP) or 105°C(MVK-BP) without voltage applied. The rated voltage shall be applied to the capacitors for a minimum of 30 minutes, at least 24 hours and not more than 48 hours before the measurements.	
	Series Name	MV-BP
	Capacitance change	≤ ± 15% of the initial value
	Tanδ	≤ ±150% of the initial specified value
Others	Leakage Current	≤ The initial specified value
	Satisfied characteristics W of KS C 6421	

### PART NUMBERING SYSTEM

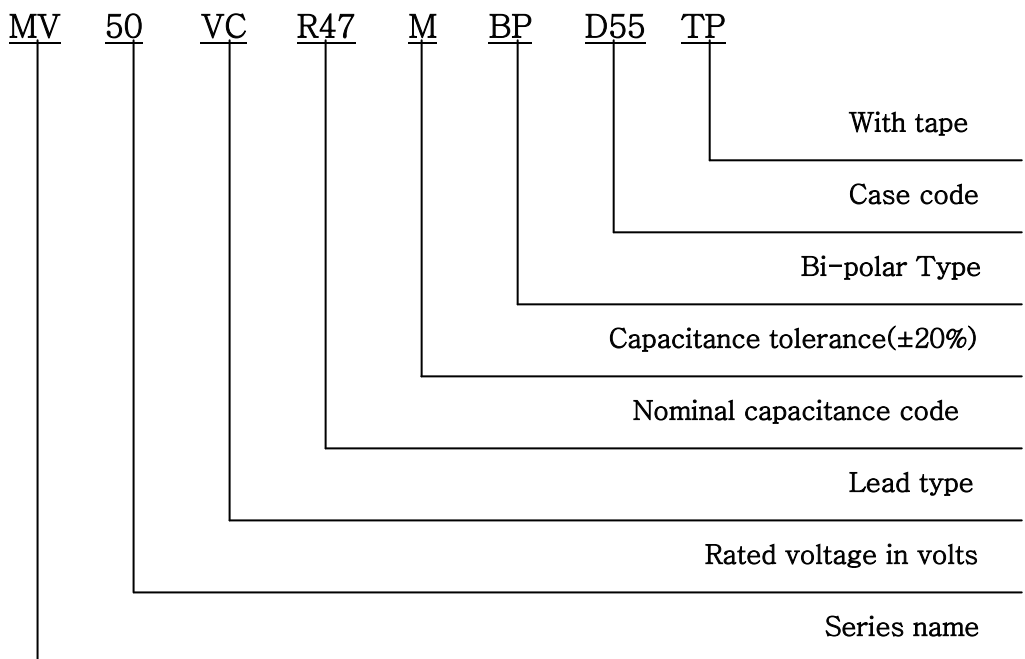

Capacitance	Code
0.1 μF	R1
0.47 μF	R47
1.0 μF	1
4.7 μF	4R7
10 μF	10
100 μF	100

**DIMENSIONS OF MV-BP, MVK-BP Series(Type:VC)**

Recommended solder land on PC board

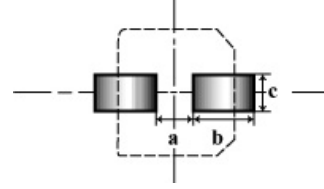
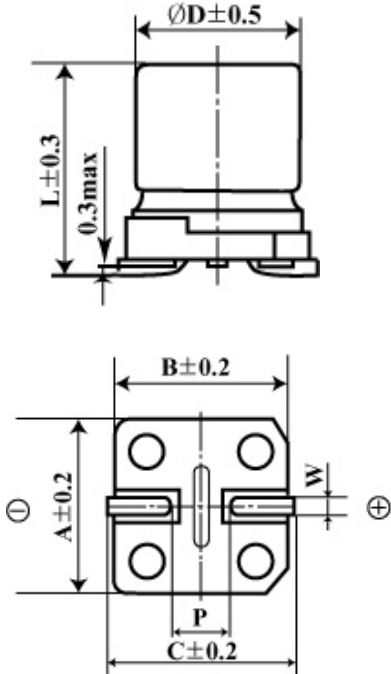

 **Sold land on PC board**

Case code	$\varnothing D$	L	A	B	C	W	P	a	b	c
D55	4	5.2	4.3	4.3	5.1	0.5~0.8	1.0	1.0	2.6	1.6
D60	4	5.7	4.3	4.3	5.1	0.5~0.8	1.0	1.0	2.6	1.6
E55	5	5.2	5.3	5.3	5.9	0.5~0.8	1.4	1.4	3.0	1.6
E60	5	5.7	5.3	5.3	5.9	0.5~0.8	1.4	1.4	3.0	1.6
F55	6.3	5.2	6.6	6.6	7.2	0.5~0.8	1.9	1.9	3.5	1.6
F60	6.3	5.2	6.6	6.6	7.2	0.5~0.8	1.9	1.9	3.5	1.6

**RATINGS OF MV-BP, MVK-BP Series**

MV-BP

$V_{DC}$ $\mu F$	4(0G)		6.3(0J)		10(1A)		16(1C)		25(1E)		35(1V)		50(1H)	
0.10													D55	1.3
(0.15)													D55	1.9
0.22													D55	2.3
0.33													D55	2.8
0.47													D55	3.4
(0.68)													D55	4.1
1.0													D55	5.5
(1.5)													D55	6.5
2.2											D55	8	E55	9
3.3									D55	9			E55	11
4.7							D55	11			E55	13	F55	14
(6.8)					D55	12			E55	15	F55	17		

10			D55	13	→	E55	18	→	F55	21		
(15)	D55	14	→	E55	21	→	F55	24				
22	→	E55	23	→	F55	28	▲ Permissible Ripple Current ▲ Case Code					
33	→	→	F55	33								
47	→	F55	36									

※ permissible Ripple Current(mArms/85°C, 120Hz)

MVK-BP

$V_{DC}$ $\mu F$	6.3(0J)		10(1A)		16(1C)		25(1E)		35(1V)		50(1H)	
0.10											D60	1.3
(0.15)											D60	1.9
0.22											D60	2.3
0.33											D60	2.8
0.47											D60	3.4
(0.68)											D60	4.1
1.0											D60	5.5
(1.5)											D60	7.5
2.2									D60	8.8	E60	10
3.3							D60	10	→	E60	13	
4.7					D60	12	→	E60	15	F60	16	
(6.8)			D60	13	→	E60	17	→	F60	20		
10	D60	14	→	E60	20	→	F60	23				
(15)	→	E60	22	→	F60	28						
22	E60	25	→	F60	32	▲ Permissible Ripple Current ▲ Case Code						
33	→	F60	35									
47	F60	39										

※ permissible Ripple Current(mArms/85°C, 120Hz)

Note : → Use next higher voltage part

Parentthesized capacitance is not standard part

## PRECAUTIONS TO USERS

### Soldering method

The capacitors of Alchip-MVG,MV,MVK and MVY series have no capability to withstand such dip or wave soldering as totally immerses a components into a solder bath.

### Reflow soldering

Use the capacitors within the Recommended Reflow soldering Conditions, and also make sure to check the temperature stress to the capacitors because the following

Makes a difference in the stress to the capacitors. If any Other reflow soldering conditions are applied, please consult us.

- ① Location of components.(The edge sides of a PC board increases its temperature more than the center does)
- ② Population of components. The less the component population is the more the temperature is increased.
- ③ Material of printed circuit board. As a ceramic board needs heating up more than a glass epoxy board to reach the same board temperature, the capacitors may be damaged.
- ④ Thickness of PC board. A thick PC board needs heating up more than a thin board. It may damage the capacitors.
- ⑤ Size of PC board. A large PC board needs heating up more than a small board, and it may damage the capacitors.
- ⑥ Location of infrared ray lamps. On IR reflow as well as hot plate reflow, heating only the reverse side of the PC board will reduce stress to the capacitors.

### Reflow of soldering

Avoid soldering more than once by reflow, Use a soldering iron for rework of solder, and do not exceed an iron tip temperature of 300℃ and a Max. exposure time of 5 seconds.

### Machanical stress

Do not lift up or push the capacitor after soldering. Avoid of the PC board. These may damage the capacitor.

### Cleaning of assembly board

For the cleaning conditions, see page 11~12. Immediately after solvent cleaning, evaporate a residual solvent for at least 10 minutes with a hot forces air. If assembly board is inadequately dried after a washing process, the capacitors will keep suffering from a residual solvent for long periods of time, and will be corrosion while in service.

### Coating on assembly board

- ① Before coating, evaporate cleaning solvents from the assembly board.
- ② Before the conformal coating, using a buffer pre coat which does not contain chloride is recommended to reduce stress to the capacitors.

### Molding by resin

Inner pressure of a capacitors slowly increases over the service life of the capacitor with gas being produced by internal chemical reaction. If end seal of the capacitor is completely be in danger. Also if the resin contains a large amount of chloride ion, it will penetrate into the end seal, get into the inside element of the capacitor, and damage the capacitor while in service.

### Others

The precautions to Users for Aluminum Electrolytic Capacitors shall be applied(page 7)

## RECOMMENDED REFLOW SOLDERING CONDITIONS

The following conditions are recommended for air or infrared reflow soldering of the surface mount capacitors onto a glass epoxy circuit board of 90×50×0.8mm(with resist) by cream solder(eutectic solder).

The temperatures shown are the surface temperature value of the top of the capacitor.

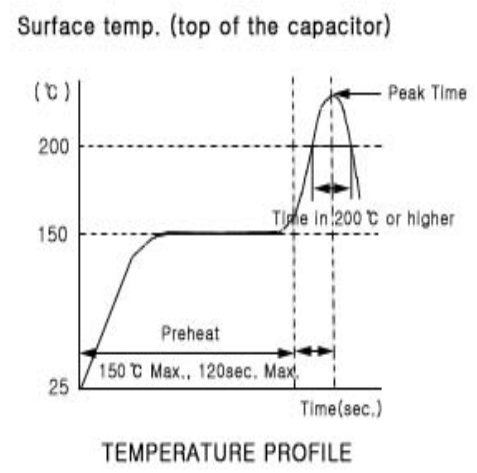
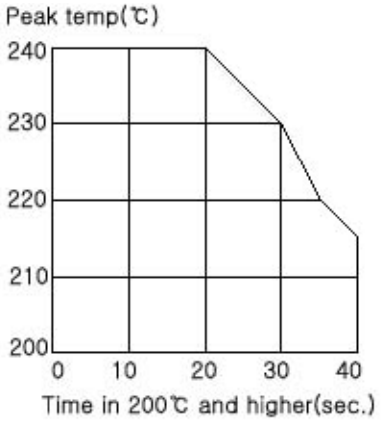
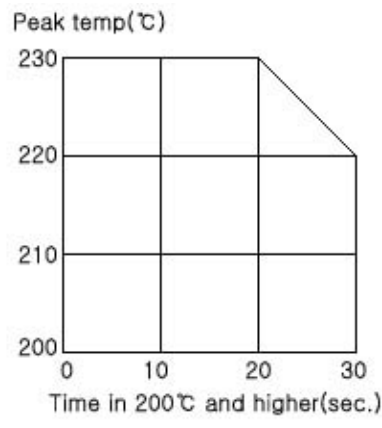
RECOMMENDED RANGE		TEMPERATURE PROFILE
Series and case code		
MV, MVG, MVK, MVY(B55 ~ F60)	MV, MVK, MVY(H63 ~ J10)	 <p style="text-align: center;">TEMPERATURE PROFILE</p>
		

RECOMMENDED RANGE OF Elogical Capacitors	
B55 ~ F80	H63 ~ J10
